

Circuit Techniques for Wireless Brain Interfaces

B. Otis*, C. Moritz†, J. Holleman*, A. Mishra*, J. Pandey*, S. Rai*, D. Yeager*, F. Zhang*

Department of Electrical Engineering, University of Washington, Seattle, WA, 98195, USA *

Department of Physiology and Biophysics, University of Washington, Seattle, WA 98195, USA †

Abstract—Efficient, miniaturized wireless recording is critical for both existing and emerging health-monitoring applications. One important example of this is in the brain interface community, where new technologies allow improved observation and understanding of brain functions. This, in turn, drives the need for ever smaller, lower power, and higher performance circuitry for chronic recording. This paper describes circuit and system techniques for low power wireless brain interfaces. Active and passive architectures are described and compared, and measured *in-vivo* data from both are presented.

I. INTRODUCTION

Neuroscientists are increasingly engaging the integrated circuit (IC) community to realize new tools for understanding the brain. Fundamental research performed on small animal models, for example, requires miniaturized instrumentation for long term freely behaving studies. Recording from non-human primates, rats, mice, and even moths (see Figure 1) is of interest. This research, in turn, will lead to advanced neuroprosthetics and brain-computer interfaces (BCI), which will demand even more functionality, robustness, and miniaturization from the electronics. Overly-conservative performance goals lead to a loss of efficiency, while overly-relaxed specifications lead to an ineffective system. Since there are no established standards, close interaction between IC designers and neuroscientists is critical.

Section II discusses the motivation and system requirements for wireless brain interfaces. Potential impacts in both fundamental research as well as in clinical environments will be examined.

We then describe two different paradigms for realizing miniaturized wireless neural interfaces: *active* vs. *passive* systems. We explore this distinction with an emphasis on wireless connectivity. Section III discusses our work in active brain interfaces. Active systems contain an internal energy source: either a small battery or energy harvester. They are capable of transmitting signals to a remote receiver and will ultimately integrate receive capability for configuration and stimulation control.

In contrast, Section IV discusses passive brain interfaces. Passive interfaces are battery-free and extract all necessary power for operation from the incoming RF wave sent by an interrogator. Unlike short-range inductively coupled power/data links, our prototype Radio Frequency

Identification (RFID)-type platform allows neural recording over a range of about 1m. We will compare the benefits and disadvantages of active and passive interfaces, discuss prototype systems, and present measured *in-vivo* data from both.

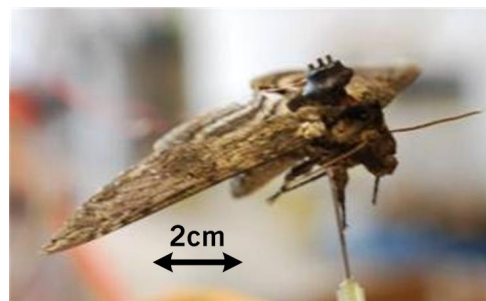

Fig. 1. Tethered *Manduca Sexta* moth. Techniques are currently in development for allowing wireless, untethered recording and stimulation on a sub-gram platform allowing remote interfacing to the central nervous system during free flight.

II. APPLICATIONS AND REQUIREMENTS OF MINIATURIZED BRAIN INTERFACES

A. Specifications

Two types of signals are generally of interest when recording within the brain of behaving animals: single-neuron action potentials and local field potentials. Action potentials, or spikes, are high-frequency events typically completing a bi-phasic waveform in 1-2 ms (see Figure 2). High-pass filters in the range of 0.5-1.0 kHz are necessary for discriminating single neuron action potentials from background activity, and sampling rates of 20-30 $\frac{kS}{s}$ are typically used for digital recording.

Local field potentials (LFPs) are lower frequency oscillations believed to reflect the sum of synaptic potentials over larger areas of cortex. Frequency bands of interest in the LPF include the Alpha (5-10 Hz), Beta (15-30 Hz) and high Gamma (80-200 Hz).

Recording single-neuron action potentials requires electronics and amplifiers with a sufficiently low noise-floor (typically a few μV_{RMS} , input-referred) to enable discrimination of microvolt signals from background activity. Signal-to-noise ratios (SNR) are often as low as 3:1, with examples in Figure 2 ranging from 4:1 to 7:1.

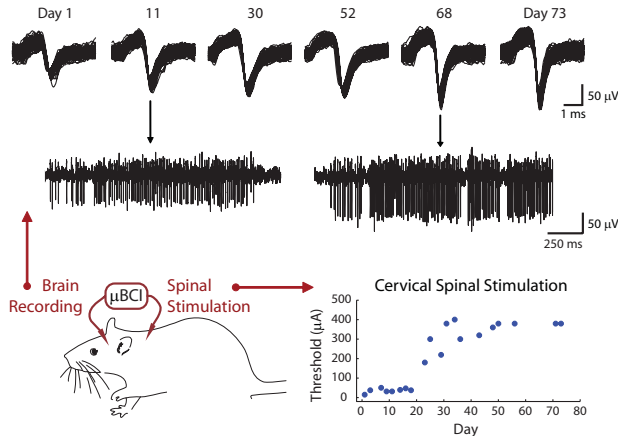

Fig. 2. Ongoing experiments using cortical activity to trigger spinal stimulation in a rat model of spinal cord injury. Single neuron action potentials from the same recording site are stable over many days despite some change in waveform amplitude (top). This brain activity will be used to trigger intraspinal stimulation to evoke forelimb movements using a μ BCI (bottom left). Threshold currents for evoking movements via spinal stimulation range from 20-500 μ A, and are stable over several weeks between occasional increases (bottom right).

B. Applications

The development of low-power, wireless, miniaturized brain-computer interfaces (μ BCI) will permit neural activity to be studied during natural, un-tethered behavior in small laboratory animals. This will enable experiments examining neural modulation and coding outside of the constrained and repetitive tasks typically studied by neurophysiologists, providing critical insight into the function of neural networks during free behavior.

In addition, miniature autonomous devices will permit the development of fully-implantable clinical systems for the treatment of nervous system disorders. For example, studies are currently underway to provide an artificial pathway bypassing damaged parts of the brain or spinal cord [1]. Neural activity recorded from the brain can be used to trigger electrical stimulation of the spinal cord below the injury (see Figure 2), or of peripheral nerves and muscles [2], to restore movement to paralyzed limbs.

A complete neuroprosthetic system would thus be capable of recording neural activity in the brain and delivering stimulation to other parts of the nervous system [3]. With new electrode technology [4], action potentials from the same neuron can now be stably recorded for several weeks [5] and possibly even several months based on waveform shape and correlation to behavior (Figure 2). This neural activity can thus serve as reliable “trigger” for stimulation of muscles or the spinal cord. Stimulation with relatively small currents (20-500 μ A; Figure 2) evokes functional movements via spinal stimulation [6], compared

to larger current required to activate peripheral nerves and muscles directly (1-10 mA).

Miniature, wireless electronics will permit a complete neuroprosthetic system to be carried by a small animal, such as a rat, and provide a continuous stimulating connection between the cortex and spinal cord (Figure 2). This stimulating circuit may provide multiple rehabilitative benefits to the damaged nervous system. The immediate benefit may be in direct activation of paralyzed muscles via this artificial circuit, as has recently been observed in monkeys [2]. Continued use of this artificial circuit may also aid in the recovery and rewiring of spared neural circuits. Connections between neurons can be strengthened by synchronous activity at two sites within the nervous system, and long-lasting changes in connectivity have been observed in the brain after similar synchronizing stimulation [7].

Fully-implantable wireless devices are a prerequisite for clinical applications of this technology. The risk of central nervous system infection is too great to permit wires or connectors to penetrate the skin for long-term applications. Following on the success of the pace maker and cochlear implant, a BCI or neuroprosthetic device will need to record signals from the brain and either transmit these signals wirelessly to a nearby receiver, or send stimuli through wires tunneled under the skin to the spinal cord or paralyzed muscles. Robust, multi-channel wireless devices for brain recording are one of the critical developments that will permit BCIs and neuroprosthetics to gain widespread clinical acceptance for the treatment of neural disorders.

III. ACTIVE NEURAL INTERFACES

A. Wireless Active Neural Recording Architecture

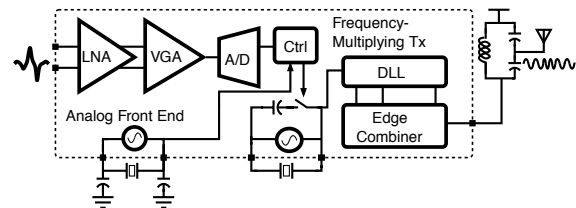

Fig. 3. Architecture of the wireless neural recording system.

In this section we describe an active chip allowing wireless digital streaming of a neural signal. As shown in Fig. 3, the neural interface comprises an analog front-end with gain variable from 40 to 78dB, an 8b successive approximation ADC, and a 100kb/s 2-FSK transmitter. The system operates in the Medical Implant Communications Service (MICS, 402 to 405MHz) and 433MHz ISM bands. To achieve high efficiency with the low output power required by the MICS standard, a frequency-multiplying transmitter is used. Low-noise amplification is achieved in a fully-differential low-noise analog front end by using

a complementary input stage. The control logic inserts synchronization bits between digital words to assist with clock and data recovery at the receiver.

B. Analog front-end

Microvolt-level signals are amplified by a low-noise amplifier over a 25mHz to 11.5kHz bandwidth. In order to simultaneously optimize PSRR, linearity, and noise efficiency, we combined a complementary-driven amplifier concept [8] with a fully-differential closed-loop architecture. Simultaneously driving the n- and pFETs of the input stage doubles the effective transconductance for a given bias current while the output noise remains constant, thus reducing the input-referred noise voltage by a factor of two. The output of the front-end is sampled by an 8-bit successive approximation (SAR) ADC, designed to operate at sample rates from 10-100 kSps. An SAR architecture was chosen for the ADC for power efficiency [9]. The use of clock gating minimizes unnecessary dynamic power consumption, while while a single-ended dynamic comparator minimizes static power consumption.

C. Sub-mW MICS-band transmitter

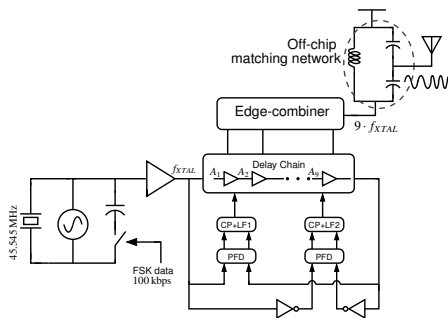

Fig. 4. MICS transmitter schematic [10].

An ultra-low power transmitter architecture was designed for 405MHz MICS-band spike-streaming applications [10]. Our transmitter architecture improves global efficiency by operating entirely at the on-chip crystal reference frequency and employs an efficient frequency multiplying power amplifier (FMPA), as shown in Fig 4(b). The low-power frequency multiplier is based on the principle of edge-combining.

For a 9X multiplication, a 9 stage DLL generates 9 equally spaced phases of the frequency reference, such that the rising and falling edges are separated by an interval of $T/18$, where T is the time period of the reference input at 44.545MHz. These combined (wire-OR'ed) edge pairs result in frequency multiplication by a factor of nine. Since the operation of the edge-combiner critically depends on equally spaced edges, we employ dual-edge locking. This technique can be generalized to other multiplication factors, determined by the number of stages in

the DLL and switching legs in the edge-combiner. The edge-combiner behaves like a high-efficiency non-linear power amplifier and produces current pulses based on overlapping edges. This current is absorbed by a tapped-capacitor LC matching network, which transforms the TX source impedance to match a 50Ω antenna. The baseband FSK data directly modulates the reference oscillator using capacitor pulling. In a prototype chip fabricated in $0.13\mu\text{m}$ process, the measured transmitter FSK deviation is 145 kHz. The transmitter consumes $400\mu\text{W}$ with a -16dBm output power at a 100kb/s data rate with an edge combiner power amplifier efficiency of 16%. Typical commercial MICS transmitters consume around 5mW, eliminating the possibility of continuous transmission with very small power sources [11]. We experimentally verified the operation of this transmitter over a distance of 15m using a commercial 400MHz antenna and off-the-shelf receiver.

D. Measurement Results

We performed *in vivo* recordings from the motor areas of a rat brain using the neural recorder's analog front end. Overlaid spikes, shown in Fig. 5, demonstrates the compatibility of the analog front end with the electrical environment presented by the *in vivo* recording context. The complete system consumes less than 1mW, allowing continuous operation from a small coin-cell battery for over a few days.

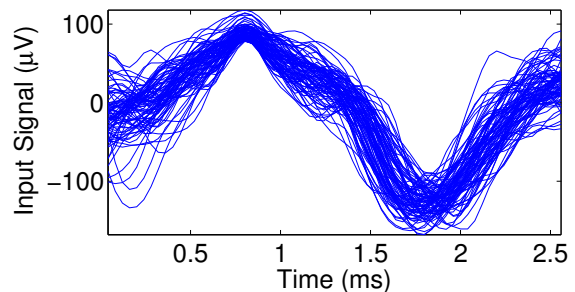

Fig. 5. Neural signals recorded *in vivo* from the motor areas of a rat brain using the analog front end described in III-B

IV. PASSIVE NEURAL INTERFACES

Providing power to implantable neural sensors is a significant challenge. If a battery is used, the power budget must be optimized so as to reduce the frequency of battery-replacement surgeries. For small animals and insects, the maximum battery payload may be too small for practical deployment. In either case, a method for wirelessly recharging the battery, or even eliminating the battery, could drastically reduce the need for surgeries as well as improve the feasibility of implantable neural sensors.

In neuroscience research, constrained environments are often acceptable, and elimination of the battery is possible if close physical proximity to a wireless power source can

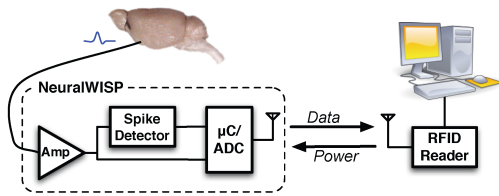

Fig. 6. System diagram of a wirelessly-powered neural sensor.

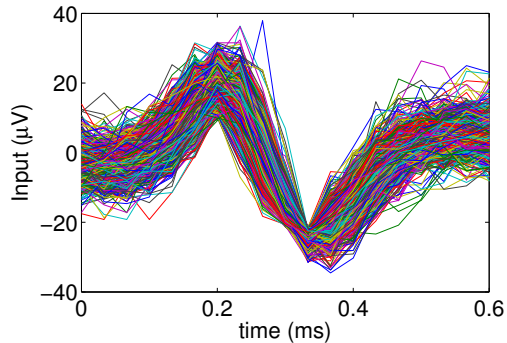

Fig. 7. Neural spikes collected from a monkey through NeuralWISP's analog front end.

be maintained by the researcher. Elimination of the battery would also allow the neural sensor to be implanted in very small animals and insects due to the reduction in size and weight. This is exciting because it allows neural recording under previously unattainable conditions.

To prototype a wirelessly-powered neural sensor, we built upon a wireless, battery-free sensing platform called WISP (Wireless Identification and Sensing Platform) [12]. WISP employs an ultra-low power, programmable MSP430 microcontroller for communication and sensing. It is powered by commercial UHF RFID readers, and communicates via EPC Class 1, Gen 2 protocol. The incoming RF power is rectified, voltage-boosted, and then stored on a capacitor, allowing a communication distance of 1m. The use of a programmable μC allows WISP to be easily configured for different applications including measurement of temperature, light level, strain, and acceleration [13]. A system diagram of the NeuralWISP is shown in Figure 6 [14]. In addition to a custom, low power, low noise neural amplifier, a programmable-threshold spike detector is used to wake the microcontroller when spikes occur.

We performed *in vivo* testing with both a moth and a monkey to validate the real-world feasibility of the NeuralWISP. A time domain trace of macaque monkey neural data recorded through the NeuralWISP analog front end is shown in Figure 7.

V. CONCLUSIONS

There is an emerging need for miniaturized low power telemetry for brain interfaces. This paper describes the

potential impact of these systems in a research and clinical setting. We draw a comparison between active and passive interfaces, and present prototype systems and measured performances of both.

ACKNOWLEDGMENT

The authors wish to acknowledge the assistance and support of Intel Corporation and National Semiconductor. We also acknowledge the contributions of Prof. Thomas Daniel, Prof. Eberhard Fetz, Prof. Steve Perlmutter, Prof. Vivian Mushahwar, and Dr. Josh R. Smith. This work was supported in part by NIH R01NS12542 and the UW Royalty Research Fund.

REFERENCES

- [1] M. H. et al., "VLSI implementation of a nonlinear neuronal model: a "neural prosthesis" to restore hippocampal trisynaptic dynamics," *Conf Proc IEEE Eng Med Biol Soc*, vol. 1, pp. 4396–9, 2006.
- [2] C. Moritz, S. Perlmutter, and E. Fetz, "Direct control of paralysed muscles by cortical neurons," *Nature*, vol. 456, no. 7222, pp. 639–42, 2008.
- [3] A. Jackson, C. Moritz, J. Mavoori, T. Lucas, and E. Fetz, "The neurochip bci: towards a neural prosthesis for upper limb function," *IEEE Trans Neural Syst Rehabil Eng*, vol. 14, no. 2, pp. 187–90, 2006.
- [4] A. Jackson and E. Fetz, "Compact movable microwire array for long-term chronic unit recording in cerebral cortex of primates," *J Neurophysiol*, vol. 98, no. 5, pp. 3109–18, 2007.
- [5] A. Jackson, J. Mavoori, and E. Fetz, "Correlations between the same motor cortex cells and arm muscles during a trained task, free behavior, and natural sleep in the macaque monkey," *J Neurophysiol*, vol. 97, no. 1, pp. 360–74, 2007.
- [6] C. Moritz, T. Lucas, S. Perlmutter, and E. Fetz, "Forelimb movements and muscle responses evoked by microstimulation of cervical spinal cord in sedated monkeys," *J Neurophysiol*, vol. 97, no. 1, pp. 110–20, 2007.
- [7] A. Jackson, J. Mavoori, and E. Fetz, "Long-term motor cortex plasticity induced by an electronic neural implant," *Nature*, vol. 444, no. 7115, pp. 56–60, 2006.
- [8] J. Holleman and B. Otis, "A sub-microwatt low-noise amplifier for neural recording," in *Proc. IEEE Engineering in Medicine and Biology Society Conference*, August 2007, pp. 3930–3933.
- [9] J. Holleman, A. Mishra, C. Diorio, and B. Otis, "A spike detector and feature extractor in $.13\mu\text{m}$ cmos," *Custom Integrated Circuits Conference, 2008. CICC'08. IEEE*, 2008.
- [10] S. Rai, J. Holleman, J. Pandey, F. Zhang, and B. Otis, "A $500\mu\text{W}$ Neural Tag with $2\mu\text{Vrms}$ AFE and Frequency-Multiplying MICS/ISM FSK Transmitter," *IEEE ISSCC Dig. Tech. Papers*, Feb. 2009.
- [11] P. Bradly, "An ultra low power, high performance medical implant communication system (mics) transceiver for implantable devices," in *IEEE Biomedical Circuits and Systems (BioCAS)*, November 2008, pp. 32–33.
- [12] A. P. Sample, D. J. Yeager, P. S. Powlledge, and J. R. Smith, "Design of an RFID-based battery-free programmable sensingplatform," in *IEEE Transactions on Instrumentation and Measurement*, vol. 57, no. 11, Nov. 2008, pp. 2608–2615.
- [13] D. Yeager, A. Sample, and J. Smith, "WISP: A Passively Powered UHF RFID Tag with Sensing and Computation," *RFID Handbook: Applications, Technology, Security, and Privacy*, 2008.
- [14] J. Holleman, D. Yeager, R. Prasad, J. Smith, and B. Otis, "Neural WISP: An Energy Harvesting Wireless Brain Interface with 1m Range," *IEEE Biological Circuits and Systems (BioCAS) Conference*, 2008.